

DIN

Технические характеристики

По вопросам продаж и поддержки обращайтесь:

Алматы (7273)495-231	Казань (843)206-01-48	Новокузнецк (3843)20-46-81	Смоленск (4812)29-41-54
Архангельск (8182)63-90-72	Калининград (4012)72-03-81	Новосибирск (383)227-86-73	Сочи (862)225-72-31
Астрахань (8512)99-46-04	Калуга (4842)92-23-67	Омск (3812)21-46-40	Ставрополь (8652)20-65-13
Барнаул (3852)73-04-60	Кемерово (3842)65-04-62	Орел (4862)44-53-42	Сургут (3462)77-98-35
Белгород (4722)40-23-64	Киров (8332)68-02-04	Оренбург (3532)37-68-04	Тверь (4822)63-31-35
Брянск (4832)59-03-52	Краснодар (861)203-40-90	Пенза (8412)22-31-16	Томск (3822)98-41-53
Владивосток (423)249-28-31	Красноярск (391)204-63-61	Пермь (342)205-81-47	Тула (4872)74-02-29
Волгоград (844)278-03-48	Курск (4712)77-13-04	Ростов-на-Дону (863)308-18-15	Тюмень (3452)66-21-18
Вологда (8172)26-41-59	Липецк (4742)52-20-81	Рязань (4912)46-61-64	Ульяновск (8422)24-23-59
Воронеж (473)204-51-73	Магнитогорск (3519)55-03-13	Самара (846)206-03-16	Уфа (347)229-48-12
Екатеринбург (343)384-55-89	Москва (495)268-04-70	Санкт-Петербург (812)309-46-40	Хабаровск (4212)92-98-04
Иваново (4932)77-34-06	Мурманск (8152)59-64-93	Саратов (845)249-38-78	Челябинск (351)202-03-61
Ижевск (3412)26-03-58	Набережные Челны (8552)20-53-41	Севастополь (8692)22-31-93	Череповец (8202)49-02-64
Иркутск (395)279-98-46	Нижний Новгород (831)429-08-12	Симферополь (3652)67-13-56	Ярославль (4852)69-52-93
Россия (495)268-04-70	Киргизия (996)312-96-26-47	Казахстан (7172)727-132	

DIN Ball Valve TEK VALVE



Product structural features

Ball valve seal acc. to DIN is applicable to the cutting and connection of pipelines medium that are used in various industries such as petroleum, chemical industry, pharmacy, chemical fertilizer, electric power industry etc under nominal pressure of PN1.6~10MPa and working temperature within -196~150°C.

Main structural features

1. The product has indication of open-close and locking system;
2. The stem has function of anti-blow out, anti fire-safe and anti-static function;
3. The part material flange, and butting weld end dimension may be selected according to current operation condition and user's requirement, so that meeting the requirement of various engineering.

Technical specification

Structural Formation: BB-BG-OS & Y
 Driving Manner: Hand-Operated
 Driving Manner: Electric-Actuated
 Design Standard: DIN3356
 Face to Face: DIN3202
 Flange Ends: DIN2543-2545
 Test & Inspection: DIN3230

Notes: The size of serial, valve connecting flange can be design according to customers' requirement

Products performance specification

Nominal Pressure (MPa)	Shell Test (MPa)	Sealing Test (MPa)	Suitable Temp(°C)	Suitable Medium
1.6	2.4	1.76	-196~150°C	Water Oil & Gas
2.5	3.75	2.75		
4.0	6.0	4.4		
6.4	9.6	7.04		
10.0	10.5	11		

DIN Floating Ball Valve

TEK VALVE

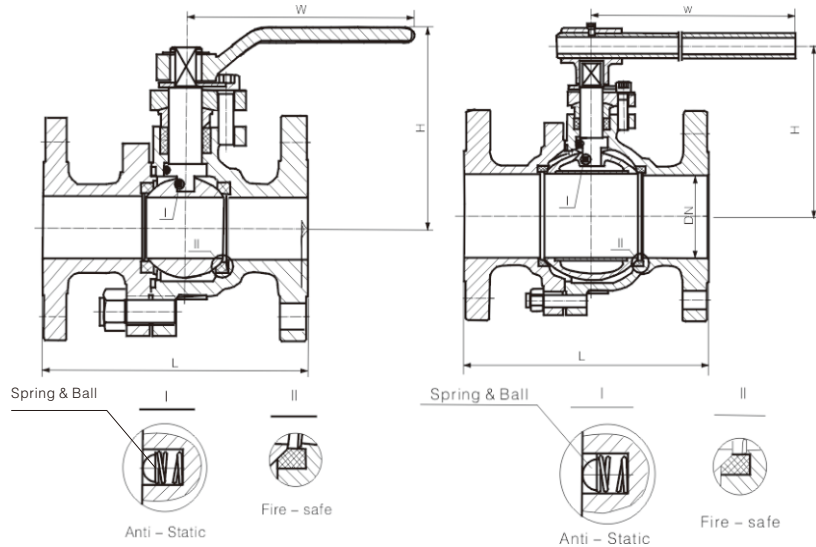

Size main dimensions of Floating Ball Valve

PN 16

DN	15	20	25	32	40	50	65	80	100	125	150	200
L	130	140	150	165	180	200	220	250	280	320	360	400
H	78	84	95	150	150	190	195	215	250	285	330	370
H1	140	160	180	250	300	350	350	400	600	600	800	1000
Wt(Kg)	3	4	5	10	14	20	25	30	40	65	73	85

PN 25

DN	15	20	25	32	40	50	65	80	100	125	150	200
L	130	140	150	165	180	200	220	250	280	320	360	400
H	78	84	95	150	150	190	195	215	250	285	330	370
H1	140	160	180	250	300	350	350	400	600	600	800	1000
Wt(Kg)	3	4	5	10	14	20	25	30	40	65	73	85

PN 40

DN	15	20	25	32	40	50	65	80	100	125	150	200
L	130	140	150	165	180	200	220	250	280	403	403	502
H	82	100	104	150	150	190	195	215	250	260	275	335
H1	140	160	180	250	300	350	350	400	600	600	800	800
Wt(Kg)	3	4	5	10	14	20	25	50	70	80	85	101

API SERIES

DIN SERIES

JIS SERIES

DIN Trunnion Ball Valve

TEK VALVE

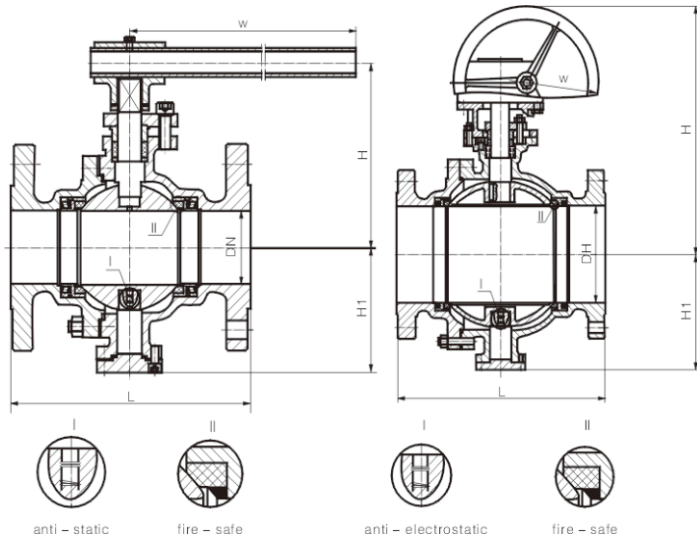

Size main dimensions of Trunnion Ball Valve

PN 16/25

DN	50	65	80	100	125	150	200	250	300	350	400	450	500	600	700	800	900	1000	
L	RF	179	191	203	229	356	394	457	533	610	686	762	846	914	1067	1245	1372	1524	1753
	BW	216	241	283	305	381	457	521	559	635	762	838	914	991	1143	1346	1524	1727	1880
H	107	125	152	178	300	330	398	495	580	625	670	698	840	1050	1100	1150	1247	1374	
H1	102	114	127	152	184	219	273	360	395	430	470	550	580	700	800	950	1100	1200	
W	230	400	400	650	1050	1050	600	600	800	800	800	800	800	800	800	800	800	800	
Wt(Kg)	12	16	22	35	58	74	205	322	460	576	864	1280	1600	3540	4500	5940	7540	9320	

PN 40

DN	50	65	80	100	125	150	200	250	300	350	400	450	500	600	700	800	900	1000	
L	RF	216	241	283	305	381	403	502	568	648	762	838	914	991	1143	1346	1524	1727	1880
	BW	216	241	283	305	381	457	521	559	635	762	838	914	991	1143	1346	1524	1727	1880
H	107	125	152	178	300	330	398	495	580	625	670	698	840	1050	1100	1150	1247	1374	
H1	102	114	127	152	184	219	273	360	395	430	470	550	580	700	800	950	1100	1200	
W	230	400	400	650	1050	1050	600	600	800	800	800	800	800	800	800	800	800	800	
Wt(Kg)	15	24	30	55	87	118	255	370	533	640	1030	1542	2100	4200	5300	7860	8684	10300	

PN 64

DN	50	65	80	100	150	200	250	300	350	400	500	600	700					
L	RF	292	330	356	406	495	597	673	762	826	902	1054	1232	1397				
	H	108	155	197	235	300	374	445	512	550	615	810	1010	1180				
H1	114	124	133	159	250	294	395	445	500	530	660	800	900					
W	600	600	600	600	600	800	800	800	800	800	800	800	800					
Wt(Kg)	23	35	49	91	192	355	640	880	1100	1540	2800	5300	5700					

PN 100

DN	50	65	80	100	150	200	250	300	350	400	500	600	700					
L	RF	292	330	356	432	559	660	787	838	889	991	1194	1397	1579				
	H	108	155	197	235	300	374	445	512	550	615	810	1010	1180				
H1	114	124	133	159	250	294	395	445	500	530	660	800	900					
W	600	600	600	600	600	800	800	800	800	800	800	800	800					
Wt(Kg)	23	38	55	102	232	290	710	960	1700	1970	3250	5800	6700					

API SERIES

DIN SERIES

JIS SERIES

По вопросам продаж и поддержки обращайтесь:

Алматы (7273)495-231	Казань (843)206-01-48	Новокузнецк (3843)20-46-81	Смоленск (4812)29-41-54
Архангельск (8182)63-90-72	Калининград (4012)72-03-81	Новосибирск (383)227-86-73	Сочи (862)225-72-31
Астрахань (8512)99-46-04	Калуга (4842)92-23-67	Омск (3812)21-46-40	Ставрополь (8652)20-65-13
Барнаул (3852)73-04-60	Кемерово (3842)65-04-62	Орел (4862)44-53-42	Сургут (3462)77-98-35
Белгород (4722)40-23-64	Киров (8332)68-02-04	Оренбург (3532)37-68-04	Тверь (4822)63-31-35
Брянск (4832)59-03-52	Краснодар (861)203-40-90	Пенза (8412)22-31-16	Томск (3822)98-41-53
Владивосток (423)249-28-31	Красноярск (391)204-63-61	Пермь (342)205-81-47	Тула (4872)74-02-29
Волгоград (844)278-03-48	Курск (4712)77-13-04	Ростов-на-Дону (863)308-18-15	Тюмень (3452)66-21-18
Вологда (8172)26-41-59	Липецк (4742)52-20-81	Рязань (4912)46-61-64	Ульяновск (8422)24-23-59
Воронеж (473)204-51-73	Магнитогорск (3519)55-03-13	Самара (846)206-03-16	Уфа (347)229-48-12
Екатеринбург (343)384-55-89	Москва (495)268-04-70	Санкт-Петербург (812)309-46-40	Хабаровск (4212)92-98-04
Иваново (4932)77-34-06	Мурманск (8152)59-64-93	Саратов (845)249-38-78	Челябинск (351)202-03-61
Ижевск (3412)26-03-58	Набережные Челны (8552)20-53-41	Севастополь (8692)22-31-93	Череповец (8202)49-02-64
Иркутск (395)279-98-46	Нижний Новгород (831)429-08-12	Симферополь (3652)67-13-56	Ярославль (4852)69-52-93
Россия (495)268-04-70	Киргизия (996)312-96-26-47	Казахстан (7172)727-132	